

DC-DC Converter AVP/Js and AVP/Jsp

Output power up to 53 Watts

Isolated – Single Output
PCB (AVP/Jsp) and Chassis Mounting (AVP/Js)



AVP/Js



AVP/Jsp

Block Diagram

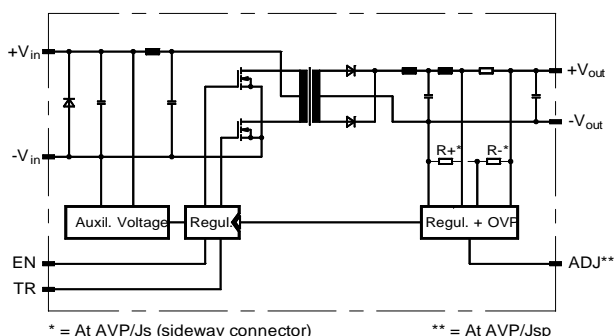

* = At AVP/Js (sideway connector)

** = At AVP/Jsp

Technology

- MOSFET design
- Regulators in surface mount technology

Special Features

- Electrostatic discharge according to EN 61000-4-2:1995 (testing level 4): 8 kV contact (base plate)/ 15 kV air
- Burst transients according to EN 61000-4-4:1995 (class 3): 2 kV
- Surge according to EN 61000-4-5:1995 (class 2): 0,5 kV symmetric
- Conducted emission:
 - Input filtering according to EN 55022:1994, class B****
- Reverse polarity protection
- Zero load operation and short circuit protected
- Parallel and series connection
- Overtemperature shutdown
- No overshoot of output voltage at switching on
- Remote off (EN) with TTL – L-signal
- Overvoltage protection in the output circuit, even in case of external supply (OVP)
- Extremely low thermal stress of sensitive components due to dissipated power loss over mounting surface
- Vibration resistant and indifferent to humidity due to encapsulated case

Specifications

at $\vartheta_{amb}=25^{\circ}\text{C}$, $V_{in\ nom}$, $0,62\ I_{out\ nom}$

Temperature

Ambient air	ϑ_{amb}	= $-40^{\circ}\text{C}...+85^{\circ}\text{C}$
Storage	ϑ_S	= $-40^{\circ}\text{C}...+100^{\circ}\text{C}$
Rise in case	$\Delta\vartheta_{C\ perm}$	$\leq 20\ \text{K}$
Permissible rise on base plate	$\Delta\vartheta_{B\ perm}$	$\leq 25\ \text{K}$
Necessary thermal resistance of mounting surface (chassis) to ambient	R_{thBA}	$\leq 4,5\ \text{K/W}$

Output voltage

Tolerance (AVP/Js)	ΔV_{out}	$\leq \pm 0,25\ (0,5)\ \%$ *
Output ripple at $\vartheta_{amb} = -40^{\circ}\text{C}...+85^{\circ}\text{C}$	$V_{out\ ripple}$	$\leq 3,5\ \%$
Temperature coefficient	TC	$\leq 0,016\ \%/K$

Regulation at $\vartheta_{amb} = -40^{\circ}\text{C}...+85^{\circ}\text{C}$

Line reg. for $V_{in\ range}$	ΔV_{out}	$\leq 2\ \text{mV}$
Load reg. static	ΔV_{out}	$\leq 10\ \text{mV/A}^{**}$
Load change (25°C)	ΔV_{out}	$\leq 85\ (40)\ \text{mV/A}^{***}$

OVP

Starting point /%	$V_{out\ off}$	$\leq 130\ \%\ V_{out\ nom}$
Admissible continuous external current	I_{ext}	$\leq 4,5\ \text{A}$

Isolation voltage-strength

In-/Output	$\geq 1,5\ \text{kVrms}$
Input to base plate	$\geq 1,5\ \text{kVrms}$
Output to base plate	$\geq 0,5\ \text{kVrms}$
Resistance In-/Output	$R_{iso} \geq 1,5\ \text{GOhm}$
Capacitance In-/Output	$C_{iso} = 2200\ \text{pF}$

Weight AVP/Js / AVP/Jsp

M	ca. 220/200 g
-----	---------------

* At 5 V double values

** At the AVP/Jsp 9 mV smaller values

*** $I_{out\ min} = 0,1\ I_{out\ nom}$. At the AVP/Jsp 5 mV smaller values

**** In built-in condition our devices may show different EMC properties

Drawings

Dimensions in mm
Tolerance: general ± 1 mm

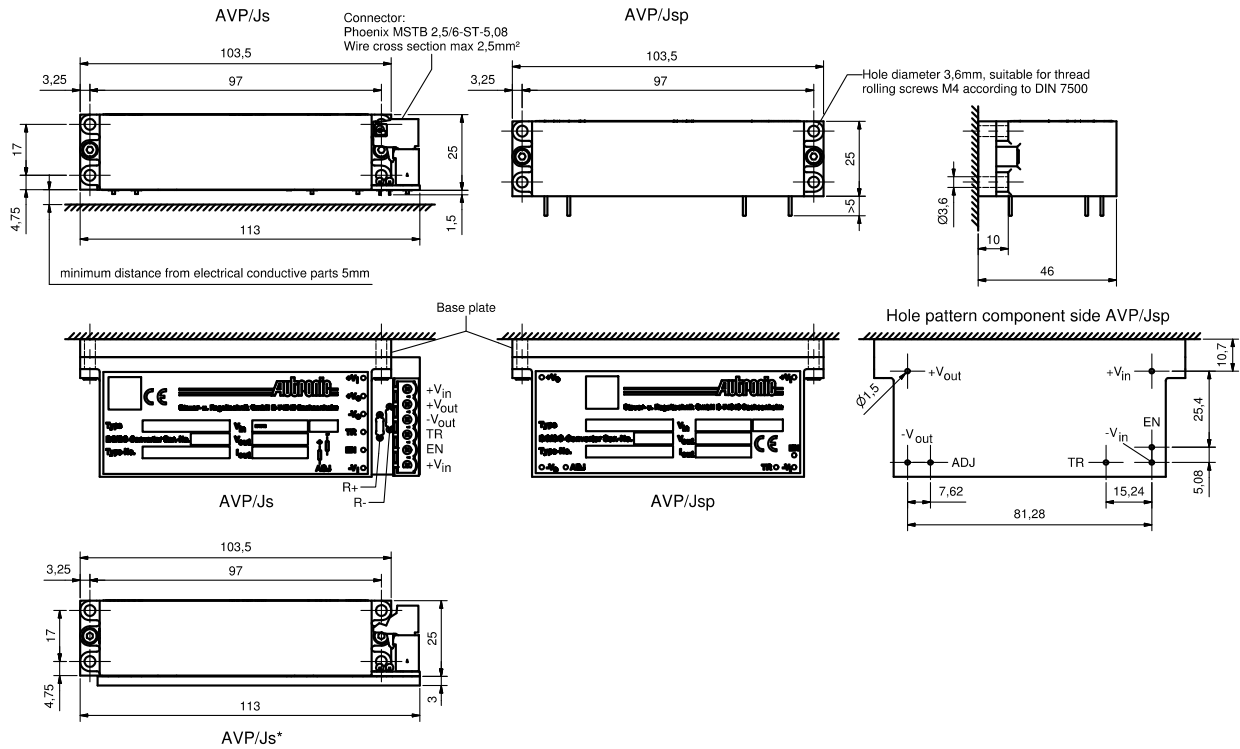

*For models with pin cover

Operating Instructions

Installation: The converters have to be installed according to the guidelines currently in force, like other open electronic component assemblies. Attention must be paid to sufficient ventilation, fastening and protection against accidental contact! The mounting surface has to be even with a thermal resistance as described under "Specifications". If more than one converter is mounted on the same mounting surface the thermal resistance has to be divided by the quantity of converters used. The base plate has to be grounded by using thread rolling screws M 4 according to DIN 7500.

Reverse polarity protection: If reverse polarity connection of the input voltage can not be excluded, an external time-lag fuse must be installed. Size: $I_{rat} = 1,5 \times I_{in\ max}$ (max. 16 A). Pay attention on sufficient current of current source in case of short-circuit!

Excess temperature protection: In case temperature exceeds 101°C , typ. 105°C , (due to inadmissible operation conditions) the output voltage is automatically switched off and restarted after cooling down about 10 K.

Overvoltage protection: Externally or internally caused overvoltage at the output leads to a thyristor-controlled short-circuit and shutdown of the output. After elimination of the overvoltage the output voltage restarts automatically.

External shut down (EN): $V < 0,8\ \text{V}$ at pin "EN" to pin $-V_{in}$ switches off the output. $I_{source} 500\ \mu\text{A}$.

Current limiting: $I_{out\ lim} = 1,1 \dots 1,2 I_{out\ nom}$. At more than 50% overload, the output switches off and restarts automatically latest after 1 s of elimination of the overload.

Tracking operation: If the TR pins of two or more converters are connected, the output voltages in case of short-circuit or overload goes synchronously down.

Adjustment: Connection of the pins "ADJ" and $-V_{out}$ for the AVP/Jsp modules or inserting a wire to "R+" for the AVP/Js modules increases the output voltage of about 8%. Intermediate values are obtained by means of a resistor. By connecting "ADJ" and $+V_{out}$ pins for the AVP/Jsp by means of a resistor i.e. adding a resistor for "R-" for the AVP/Js ensure that the output may be lowered by max. 8%.

Standard converters AVP/Js and AVP/Jsp

V _{out} V	I _{out nom} ²⁾ A	V _{in nom} V	V _{in range} V	I _{in max} A	η ³⁾ %	f kHz	Order Number	
							AVP/Js	AVP/Jsp
5 ¹⁾	4,8	12/24	5...36 ⁴⁾	6,7	78	67	09 36 81 0112 2	09 36 81 0172 2
	6,4	12/24	9...40	4,8	81		09 36 61 0112 6	09 36 61 0172 6
	8,0	24	15...36	3,4	84		09 36 91 0112 9	09 36 91 0172 9
	8,0	48	32...74	1,6	82		09 36 51 0112 8	09 36 51 0172 8
	8,0	110	66...154	0,8	82		09 36 71 0112 4	09 36 71 0172 4
12	2,1	12/24	5...36 ⁴⁾	6,7	79	67	09 36 82 0112 1	09 36 82 0172 1
	2,9	12/24	9...40	4,8	83		09 36 62 0112 5	09 36 62 0172 5
	4,0	24	15...36	3,7	88		09 36 92 0112 8	09 36 92 0172 8
	4,0	48	32...74	1,8	86		09 36 52 0112 7	09 36 52 0172 7
	4,0	110	66...154	0,9	86		09 36 72 0112 3	09 36 72 0172 3
15	1,6	12/24	5...36 ⁴⁾	6,4	80	67	09 36 83 0112 9	09 36 83 0172 9
	2,2	12/24	9...40	4,6	84		09 36 63 0112 4	09 36 63 0172 4
	2,2	12/24	9...40	4,6	84		09 36 63 0119 5 ⁵⁾	-
	3,2	24	15...36	3,7	89		09 36 93 0112 7	09 36 93 0172 7
	3,2	48	32...74	1,8	86		09 36 53 0112 6	09 36 53 0172 6
	3,2	110	66...154	0,9	86		09 36 73 0112 2	09 36 73 0172 2
24	1,1	12/24	5...36 ⁴⁾	7,2	80	67	09 36 84 0112 8	09 36 84 0172 8
	1,4	12/24	9...40	4,7	85		09 36 64 0112 3	09 36 64 0172 3
	1,4	12/24	9...40	4,7	85		09 36 64 0119 4 ⁵⁾	-
	2,1	24	15...36	3,9	89		09 36 94 0112 6	09 36 94 0172 6
	2,1	48	32...74	1,8	87		09 36 54 0112 5	09 36 54 0172 5
	2,1	110	66...154	0,9	87		09 36 74 0112 1	09 36 74 0172 1
30	1,0	12/24	5...36 ⁴⁾	7,7	80	67	09 36 85 0112 7	09 36 85 0172 7
	1,3	12/24	9...40	5,1	85		09 36 65 0112 2	09 36 65 0172 2
	1,75	24	15...36	4,0	89		09 3 6 95 0112 5	09 36 95 0172 5
	1,75	48	32...74	1,9	85		09 36 55 0112 4	09 36 55 0172 4
	1,75	110	66...154	1,0	85		09 36 75 0112 9	09 36 75 0172 9

1) Adjusted to 5,1 V

2) For $\theta_{amb} = -40^{\circ}\text{C} \dots 55^{\circ}\text{C}$. Derating from 55°C to 85°C : 1,25%/°C
At θ_{amb} between 85°C and 95°C linear decreasing to 0 A

3) At $V_{in nom}$ and $0,6 I_{out nom}$

4) In case of operation at $V_{in} < 7$ V basic load is required

5) With pin cover

Models in blue are not recommended for new designs.

Models in red are obsolete.

Autronic Steuer- und Regeltechnik GmbH
Siemensstr. 17
D-74343 Sachsenheim
Tel. +49 (0) 7147/24-240
Fax +49 (0) 7147/24-252
<http://www.autronic.de>
E-Mail: vertrieb@autronic.de
DIN EN ISO 9001 certified