

Terminology and Basic Test Conditions for GAIA CONVERTER DC/DC Modules



1- General

This application note describes correct techniques when checking the GAIA Converter DC/DC modules as per the electrical specifications listed with the datasheet.

This application note must always be read with datasheet and specific application note of the module under test.

DC/DC converters are complex electronic

subassemblies that can easily have over 50 parameters specified on a datasheet. Accuracy testing is important not only at design stage but also at production stage and incoming inspection.

This application note describes also the GAIA converter basic terminology to address DC/DC converter parameters.

2- Block diagram of Gaia Converter DC/DC modules

The Gaia Converter modules are feedback controlled flyback converters using current mode Pulse Width Modulation (PWM). The configuration uses a single transistor and a flyback diode. The output voltage is monitored by a separate

transformer winding close to the secondary windings and fed back to the control circuit. The following schematics resumes the block diagram for single and dual output types.

6

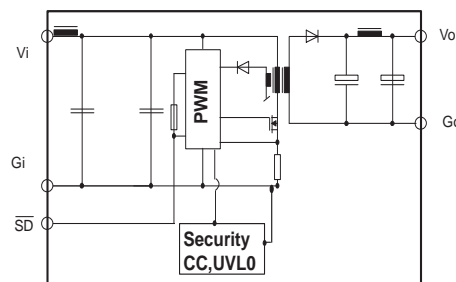

Figure 1 :
Single output type block diagram

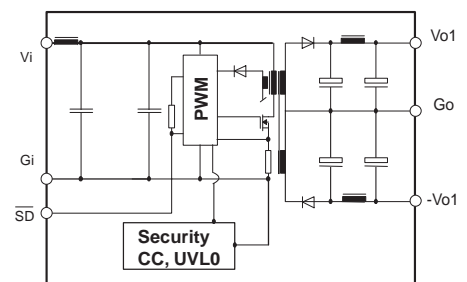

Figure 2 :
Dual output type block diagram

3- Recommended Test Conditions

3-1 Equipment and Set-Up

Figure 3 there after depicts a general equipment set-up for testing DC/DC converter. This set-up is sufficient to test the majority of electrical parameters.

All connections should be made with great attention especially at the output pins. Leads connection with alligator clips and similar terminations should be avoided.

The accuracy / stability of the equipments should be at least 10 times the resolution required to measure a parameter. In general digital meters should be 4 1/2 digit and oscilloscopes should have 20 to 100 MHz bandwidth.

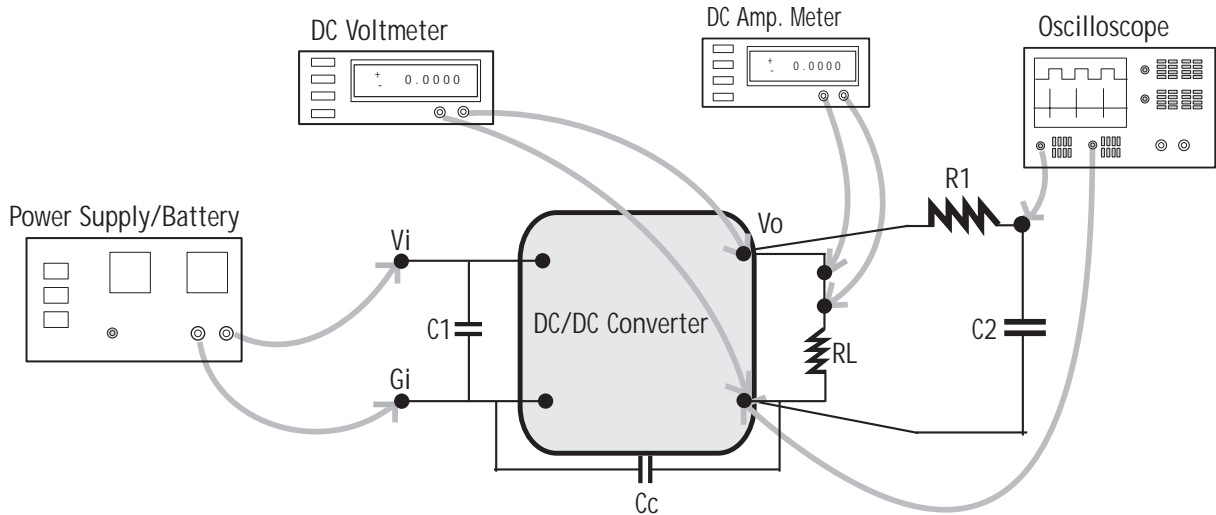

Figure 3. Test Set-Up

Where :

- Vi = Input Voltage (Min-max)
- Vo = Output Voltage
- C1 = 4.7-10 μ F chemical capacitor
- C2 = 680pf/63V ceramic capacitor
- Cc = 10nf common mode capacitor
- R1 = 47 W/ 1/4W Resistor
- RL = Min-Max (variable load) see schematic
- Test = Coaxial connector to measure ripple/noise

Note for the capacitance Cc : A common mode capacitor is used for improved EMI and noise level performance of the GAIA Converter modules. The voltage rating decides the isolation level. The common mode capacitor Cc must be connected as close as possible between input ground and output ground pins.

Note for the filter R1/C2 : R1/C2 filter is used to filter «ambient noise» due to wiring cable and connections; frequency is 5MHz. If the oscilloscope integrates such a filter, the R1/C2 is not necessary. C2 and co-axial connector must be as close as possible.

Variable Load RL (typical schematic) :

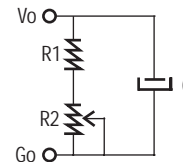

Where :

$$R1 = \frac{Vo^2}{Pmax}$$

$$R2 \text{ (Variable Resistor)} = \frac{[Vo]^2}{Pmax/4} - R1$$

(Power rating of R1 and R2 should be >Rxlmax²)

C = 47 μ F-100 μ F/63V capacitor

Please make sure that RL is connected to the output pins of module under test and not after resistance R1 of the test schematic.

3- 2 Measurement Precaution

To measure set point accuracy, load regulation and line regulation, it is necessary to apply the probe of the digital multimeter directly on the output pins of the module under test.

4- GAIA Converter DC/DC Converter Terminology

Ambient Temperature

The temperature in the area around a converter and which is measured at some distance from the device so that it is considered uniform.

Case Temperature

The temperature of a converter measured at the center of the case. Temperature ratings for converters are usually given for the case temperature.

Common Mode Capacitance

The common capacitance is a capacitance connected between input ground and output ground and allows to decrease common mode noise. GAIA Converter does not include common mode noise capacitance inside the module and recommend to users to include it externally. Value and details are given in individual GAIA Converter datasheet.

Common mode noise

The component of noise which is common to both the DC input and input return or output and output return with respect to a common reference. The common reference is generally the converter's metal case (see GAIA Converter dedicated application note).

Cross Regulation

On multiple output power supplies, the change (measured in percentage) of the nominal output voltage on one output while the load is varied on another output over specified limits. GAIA converter specifies a variation of 25% to 100% load on one output while the other is set at 75% load.

Derating with case temperature

The specified reduction in output power/current as a function of case temperature above the maximum full load rated case temperature. Derating curves are given in the datasheet.

Efficiency

The ratio of power delivered to power consumed, expressed as a percentage. Efficiency is a variable of different parameters including load, input voltage and temperature. GAIA converter specifies a typical efficiency given at nominal load (75% of full load), nominal input and at 25°C ambient temperature.

EMI (Electromagnetic Interference)

Conducted or radiated noise which is emitted from switching power supplies.

Hold-up Time

The length of time a power supply will maintain its output voltage within specifications after loss of its input power.

Input Filter

A low pass filter at the input of a DC/DC converter which can attenuate input line noise fed into the supply or reflected line ripple current generated by the supply. All GAIA Converter modules include input filter.

Input/Output Capacitance

The effective barrier capacitance from the input pins to the output pins.

Input Ripple Current (or Reflected Ripple Current)

The magnitude of the ac current generated at the input of a DC/DC converter by the switching operation of the converter, measured in milliamps peak-to-peak. GAIA Converter specifies input ripple current at full load over a band-width of 20 Mhz.

Input Transients

Temporary changes (generally in ms) in the input bus which may fall outside the maximum input voltage range of the converter. Those which exceed the maximum ratings may damage the converter.

In general, GAIA Converter specifies maximum admissible transient for each DC/DC converter.

Permanent Input Voltage Range

The permanent input voltage range over which a DC/DC converter is guaranteed to meet its specifications.

Isolation Resistance

The electrical separation between the input and output of a power supply by means of a transformer. Isolation is usually expressed in megaohms.

Isolation Voltage

The guaranteed maximum AC or DC voltage which can be applied from input to output of a power supply while the

supply maintains the specified isolation resistance in megohms.

Leakage Current

The AC or DC current flowing from input to output and/or case of an isolated power supply at a specified voltage and frequency.

Line Regulation

The change in output voltage (expressed in percentage of output voltage) as the input voltage is varying over its specified range. Line regulation is measured for GAIA modules at full load. The formula for line regulation in % is :

$$\pm \frac{[V_o(V_{imax}) - V_o(V_{imin})]}{2 \times V_o} \times 100$$

Where $V_o(V_{imax}) - V_o(V_{imin})$ is the output voltage variation for an input voltage varying from V_{imin} to V_{imax} and V_o is the nominal output voltage.

Load Regulation

The change in output voltage (expressed in percentage of output voltage) as the load is varying from a specified minimum load to full load. Load regulation is usually measured at nominal input voltage.

The formula for load regulation in % is :

$$\pm \frac{[V_o(I_{imax}) - V_o(I_{imin})]}{2 \times V_o} \times 100$$

Where $V_o(I_{imax}) - V_o(I_{imin})$ is the output voltage variation from a specified minimum load to maximum load and V_o is the nominal output voltage. In general GAIA Converter specifies load regulation from 25% to full load.

Low Line Voltage (Brown out)

The lowest input line voltage at which a power converter's output voltage will drop below the specified minimum output voltage.

Maximum Output Current (or full load)

The maximum steady-state current a converter is guaranteed to supply while continuing to meet its other requirements.

MTBF (Mean Time Between Failures)

The failure rate of a power supply, calculated using MIL-HDBK-217 for military or aerospace applications. MTBF calculations (expressed in hours) vary widely depending on assumptions made about the quality of components and assembly, number of interconnects, packaging methods, case temperature, and operating environment.

Switching Frequency

In a switching power converter, the frequency at which the power switch chops the incoming DC.

Output Current Limiting

An output protection feature in which the output current is limited to a predetermined maximum value under overload and/or short circuit conditions.

Output Power

The maximum steady-state power which the converter is guaranteed to be able to deliver to the load while continuing to meet its other specifications.

Output Trim

On adjustable output power converters, the maximum allowable adjustment of the output voltage, often expressed as a percentage of the nominal output voltage. Output trim is used to compensate for connections induced drops.

Output Voltage (or Nominal Output Voltage)

The nominal DC voltage at the output terminals of a DC/DC converter.

Output Voltage Ripple

The magnitude of the ac voltage on the output of a converter, measured in millivolts peak-to-peak over a specified bandwidth. GAIA Converter specifies output voltage ripple at full load and 20 MHz bandwidth.

Output Overload Protection

An output protection feature which limits the output current of a power supply under overload conditions so that the supply will not be damaged.

Output Overvoltage Protection

A feature which limits the output voltage or inhibits a power supply when its voltage exceeds a specified level.

Post Regulation

Use of a linear regulator on the output of a switching power supply to improve regulation and reduce ripple voltage.

Pulse Width Modulation (PWM)

A method of controlling the power switches in a switching power supply by varying the duty cycle of the switches while holding the switching frequency constant.

Remote Sensing

A method of regulating the output voltage of a power supply at the load by using sensing leads which carry very little current, thereby compensating for voltage drops in the load leads.

Return

The common input or output terminal of a power supply. It carries the return current for the terminals. Often referred to as "common."

Reverse Polarity Protection

A feature which protects a power supply against damage from a reverse polarity voltage applied at the input or output terminals. causes the output voltage to rise gradually to its nominal value.

Short Circuit Protection

A feature which limits the output current of a power supply under short circuit conditions in order to prevent damage to the supply.

Soft Start

A feature which limits the start-up current of a switching supply and causes the output voltage to rise gradually to its nominal value.

Standby Current (or No Load Input Current)

The no-load or shutdown input current of a power supply.

Static Precision

Overall precision of output voltage for a batch of same DC/DC Converter reference. GAIA Converter specifies static precision at nominal input and 75% load.

Start Up Time

The maximum time required for the output voltage of a converter to settle within the specified tolerance after initial application of the nominal input voltage. GAIA Converter specifies start-up time at full load and when output voltage reaches 90% of nominal value.

Synchronization

A switching power supply feature in which the internal switching frequency can be synchronized with an external clock within specified limits.

Temperature Range, Operation

The temperature range within which a power supply can be operated while meeting specified performance characteristics. The operating temperature range is usually specified for case temperature rather than ambient temperature.

Temperature Range, Storage

The ambient temperature range within which a power supply can be stored with no subsequent degradation of its operating specifications.

Thermal Resistivity

The measure of opposition to heat flow for a particular material or materials ($^{\circ}\text{C}/\text{W}$). GAIA Converter specifies a value in worst case conditions in confined air ambient.

Thermal Protection

A power supply safety feature which shuts the device down in the event of excess internal temperature.

Topology

The basic configuration of a circuit. DC/DC Converter topologies are usually :

- Boost Converter
- Buck Converter
- Flyback Converter
- Push-Pull Converter
- Quasi-Squarewave Converter

Undershoot/Overshoot

A transient change in output voltage outside of a power supply's minimum/maximum specified output voltage for continuous operation. It is caused by a step change in line or load.



For more detailed specifications and applications information, contact :

International Headquarters
GAIA Converter - France
ZI de la Morandière
33185 LE HAILLAN - FRANCE
Tel. : + (33)-5-57-92-12-80
Fax : + (33)-5-57-92-12-89

North American Headquarters
GAIA Converter Canada, Inc
4038 Le Corbusier Blvd
LAVAL, QUEBEC - CANADA H7L 5R2
Tel. : (514)-333-3169
Fax : (514)-333-4519

Represented by :